

# Multi Base MB-100

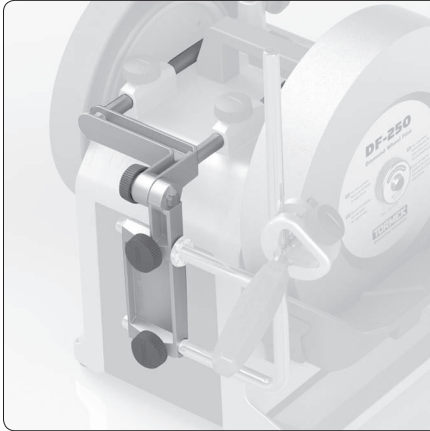

- With the MB-100, you can sharpen on the side of Tormek's Diamond Wheels to achieve a flat grinding bevel.
- Can be used with the Tormek jigs for knives, axes, woodturning tools, carving tools, chisels and plane irons.
- Can be used in both the horizontal and vertical locations.
- Fully adjustable so you can find the optimal position for each tool.

## Positioning of Machine

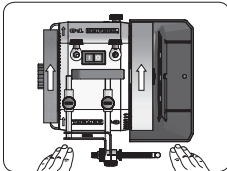

When MB-100 is mounted horizontally.

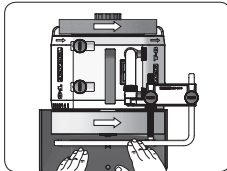

When MB-100 is mounted vertically.

With the Multi Base MB-100, you can sharpen on the side of the Tormek Diamond Wheels, thus creating a completely flat bevel that is preferable in some applications. The MB-100 has an adjustable joint that allows you to fix the sharpening position based on the optimal setting for each tool and jig. For convenience, the MB-100 can be mounted either vertically or horizontally.

The MB-100 can be used with the Tormek jigs: SVM-45 Knife Jig, SVM-140 Long Knife Jig, SVM-00 Small Knife Holder, SVX-150 Scissors Jig, SVA-170 Axe Jig, SVS-38 Short Tool Jig, SVD-186 Gouge Jig, SVS-50 Multi Jig, SE-77 Square Edge Jig and SVD-110 Tool Rest.

**Note** The MB-100 is only designed for sharpening with Tormek Diamond Wheels. It is not suitable for grinding stones as they would require truing which is not possible on the side.

Sharpening position

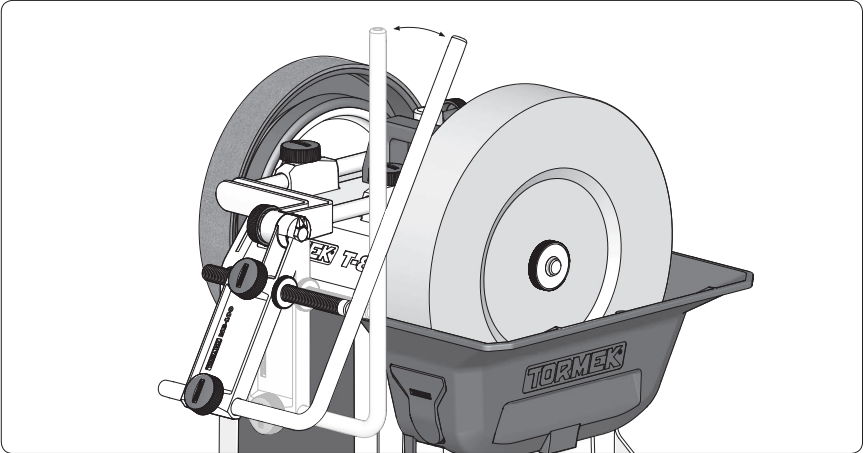
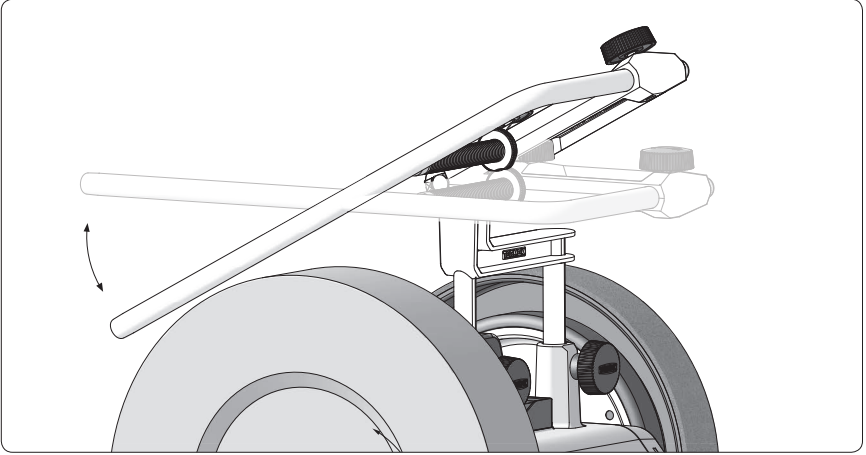

With the vertical and horizontal mounting, the sharpening position can be adjusted. This will never affect the angle setting.

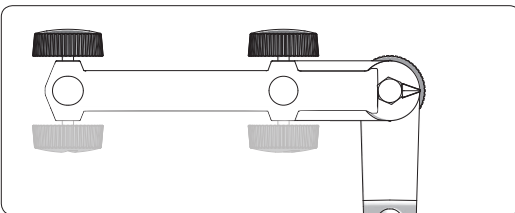

Move the locking knobs and mount on any side of the Multi Base to facilitate locking in the vertical and horizontal positions.

## Setting the edge angle

When setting the sharpening angle with the updated WM-200 AngleMaster, use the top angle scale, marked with MB-100 (1). When setting the sharpening angle with the previous WM-200, add 18° to your preferred angle (2). For example, if you are going to sharpen a chisel to a 25° angle, add 18° on the AngleMaster, i.e. 43°. **Always** set the wheel diameter compensator on WM-200 to 250 mm when sharpening with the MB-100.

### 1. Setting with the updated WM-200

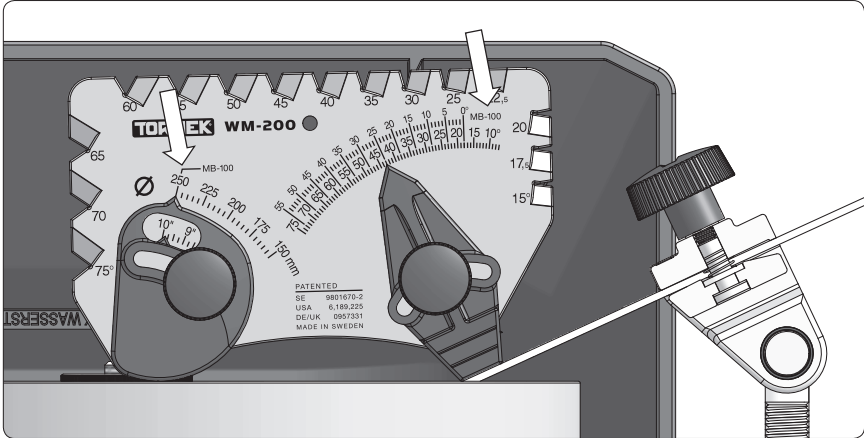

Use the top angle scale, marked with MB-100.

### 2. Setting with the previous version of WM-200

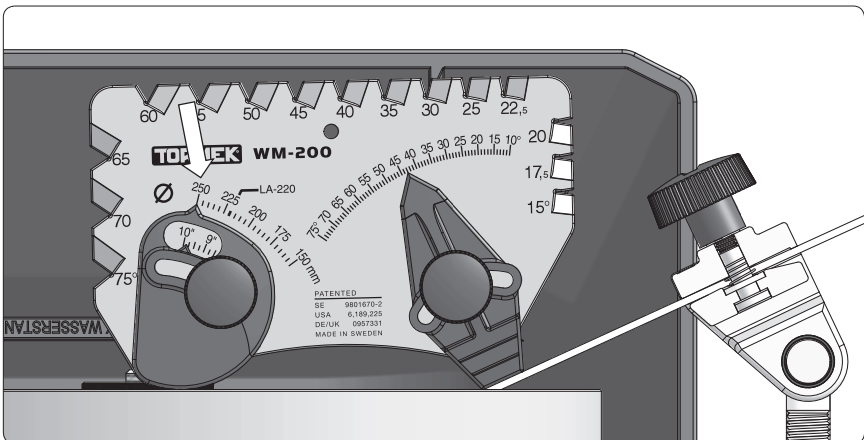

Add 18° to your preferred angle.

## Micro Adjust

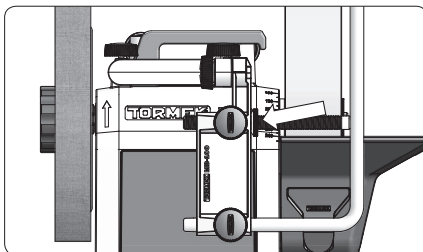
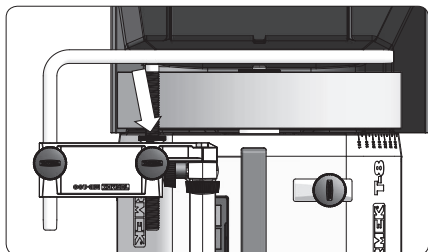

The edge angle is set by using the Micro Adjust on the Universal Support. Other settings on the MB-100 does not affect the angle.

## Sharpening

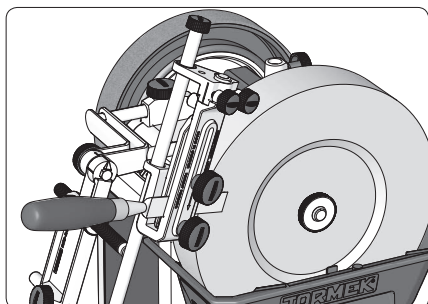

Example shows sharpening a chisel with the SE-77 jig.

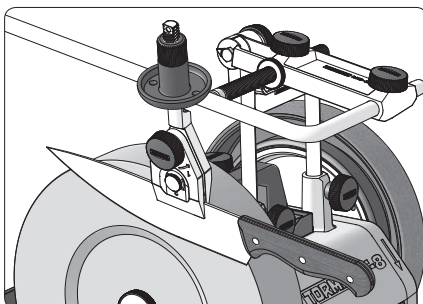

Example shows sharpening a knife with the SVM-45 jig.

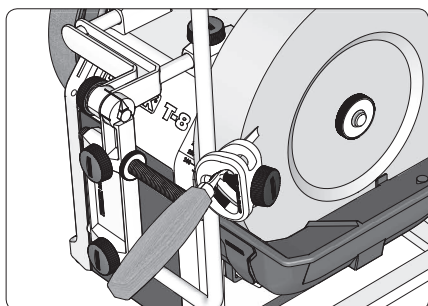

Example shows sharpening a V-tool with the SVS-38 jig.

**Tip** When sharpening with Multi Base MB-100, it can be beneficial to work closer to the Diamond Wheel for better control. Try and adjust the height of the machine if necessary or sit down when sharpening.